

ITEM NO.	PART NO.	CAT. NO.	DESCRIPTION	DWG NO.
1	P63612C	MGA-345-BC	MUL. GUY HOOK	PC2083C

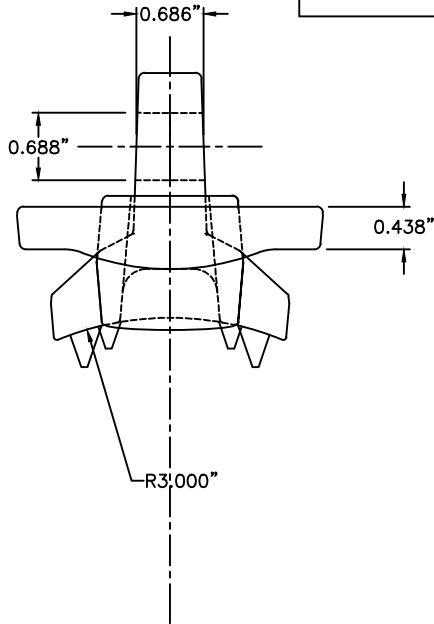

**NOTES:**

- 1.0 MATERIAL—DUCTILE IRON PER ASTM A-536,
- 2.0 COATING—HOT DIP GALVANIZE PER ASTM A-153.
- 3.0 PART NO. — MGA345, (F413910)  
LESS TEETH — MGA345N, (F413950)
- 4.0 EST. WEIGHT — 1.57 LBS.
- 5.0 RATED STRENGTH — 20,000 LBS.
- 6.0 DIMENSION IN INCHES.

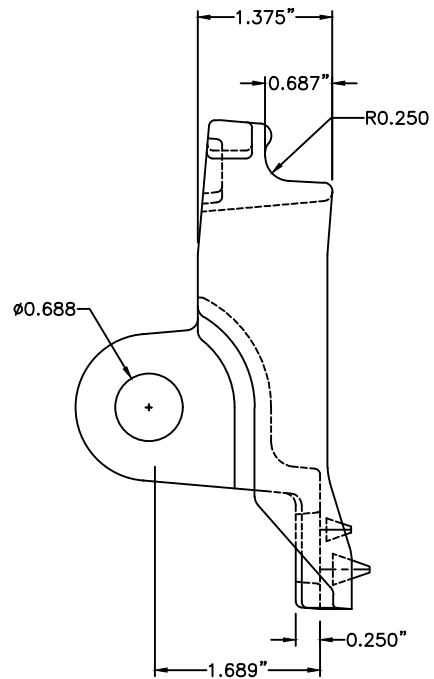
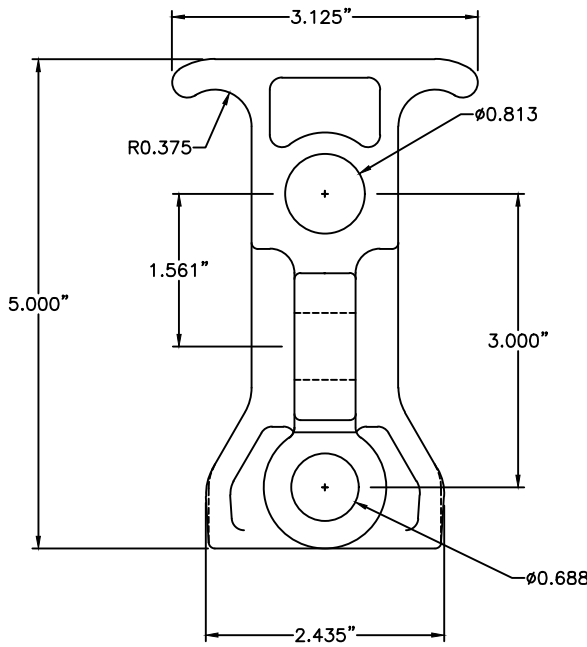

MacLean Power Systems  
BIRMINGHAM , ALABAMA

DRAWN BY:  
JWF

APPROVED BY:  
CHECKED BY:

SCALE:

MGA345 & MGA345N  
Multiple Guy Attachment

NO.	DATE	DESCRIPTION	BY
1	6/28/21	ADDED BOM TABLE	EDB
REVISIONS			

DATE: 6/02/08

DRAWING NO:  
CEA-3688

R/1